

4

3

2

1

B

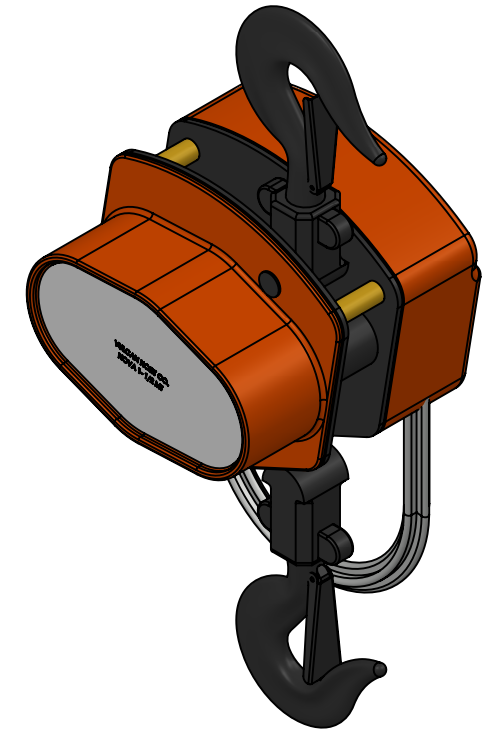
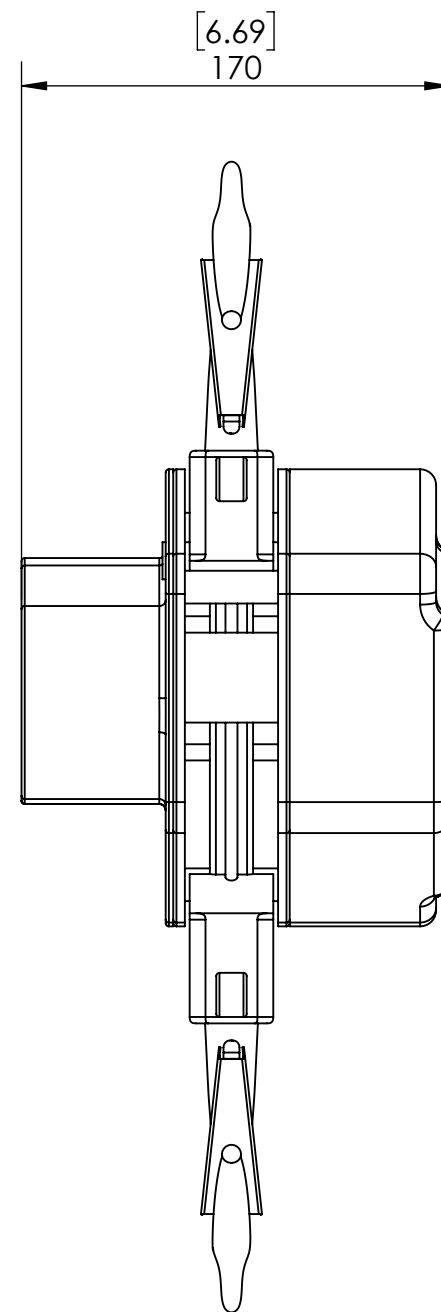
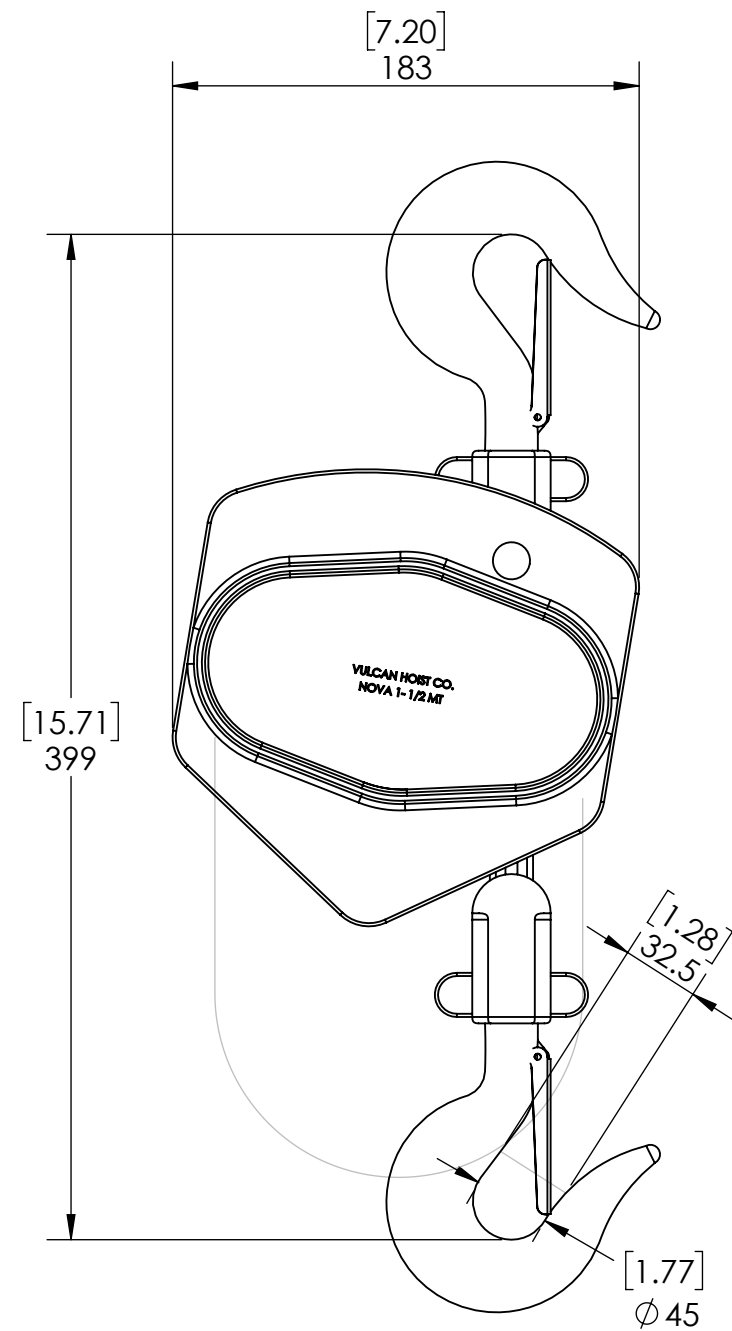

B



VULCAN HOIST - PALAN
3435 CREMAZIE E.
MONTREAL, QC H1Z 2J2
T. 514-728-4527
F. 514-374-4231
INFO@VULCANHOIST.COM
WWW.VULCANHOIST.COM

PROJECT/PROJET

TITLE/TITRE

Nova Chain Block 1.5T

SIZE/TAILLE DRAWING NUMBER/NUMÉRO DE DESSIN

B

NB1.5T

A

MATERIAL/MATÉRIEL

TOLERANCES

FRACTION	±1/64"	.X	±.02
ANGLE	±.5°	.XX	±.01
X	±.05	.XXX	±.005

DRAWN BY
DESSINÉ PAR

PROJECTION

INSPECTED BY
INSPECTÉ PARUNITS
UNITÉSAPPROVED BY
APPROUVÉ PAR

THE INFORMATION CONTAINED IN THIS DRAWING IS THE SOLE PROPERTY OF VULCAN HOIST. ANY REPRODUCTION IN PART OR AS A WHOLE WITHOUT THE WRITTEN PERMISSION OF VULCAN HOIST IS PROHIBITED.

L'INFORMATION SUR CE DESSIN EST LA PROPRIÉTÉ EXCLUSIVE DE VULCAN HOIST - PALAN. TOUTE REPRODUCTION DU DESSIN EN PARTIE OU DANS SON ENSEMBLE SANS LA PERMISSION ÉCRITE DE VULCAN HOIST - PALAN EST INTERDITE.

DATE:

SCALE/ÉCHELLE: 1:3

PAGE: 1 / 1

A

CAPACITÉ CAPACITY (MT)	NOMBRE DE RETOMBÉE NUMBER OF FALL	EFFORT NÉCESSAIRE POUR LEVER LA CHARGE MAX. EFFORT TO LIFT MAX. LOAD [LBS](KG)	DISTANCE DE DÉPLACEMENT DE LA CHAÎNE À MAIN POUR 1 PI DE LEVAGE MOVING DISTANCE FOR HAND CHAIN WHEN LIFTING 1 FT (FT)	POIDS NET (SANS CHAÎNE) NET WEIGHT (WITHOUT CHAIN) [LBS](KG)	POIDS AJOUTÉ PAR PI DE CHAÎNE DE LEVAGE WEIGHT ADDED BY FT OF LIFT CHAIN [LBS](KG)
1.5	1	[80.5] 36.5	55.6	[21.4] 9.7	[1.5] 0.7

4

3

2

1

A